



FOR A BETTER WORLD
PRODUCT INTRODUCTION

SHENZHEN INTERSKY CO., LTD
win-win Cooperation



ROOM 228A, 2ND FLOOR WEST, SCIENCE AND TECHNOLOGY INDUSTRIAL BUILDING, #6 KEYUAN ROAD, HI-TECH PARK, YUEHAI NANSHAN, SHENZHEN, CHINA.

SALES@SZINTERSKY.COM

+86 186 7552 1565

WWW.SZINTERSKY.COM

Waterproof Distribution Box

TY-DB11X Multi-Function

Brief Introduction

TY-DB11X series waterproof distribution box with compact design, extensive application sceneries and convenient, safe and good appearance features. Seal ring assemblies, Snap Joint assemblies, Surface enclosure flame retardant and Galvanized Rail assemblies can effectively provide the convenient installation and safe operation environment. Widely used in residential decoration, commercial and official etc. indoor or outdoor area.



Installation Accessories

Option installation accessories (cost will be different based on the accessories) :



2P PG connectors



4PCS M8*40mm Expand plug
4PCS ST5*35mm Self-tapping screw



4pcs Self tapping screw for cover and base fixing



MCB/RCBO/ELCB as required



Rail way for MCB

Each distribution box is packed in a plastic bag, then in a carton, the carton is sealed by tape and tie.

Model	Product Dimension (mm)	QTY in one carton (pcs)	QTY in one carton (pcs)	Carton Dimension (cm)	G.W of One Carton (kg)
TY-DB11-5	118.8*158.9*90.58	2-5	40	49*33*48	13
TY-DB11-8	200.8*145.8*91.8	8	30	48*41.5*48.5	14
TY-DB11-12	250*195*110	12	20	52.5*40.5*57	16
TY-DB11-15	310*195*110	15	20	63*40.5*57	18.5
TY-DB11-18	365*195*110	18	20	74*40.5*57	21
TY-DB11-24	360*280*110	24	10	56.5*36.5*56.5	15



INTERSKY
PRODUCT INTRODUCTION

www.szintersky.com

Components

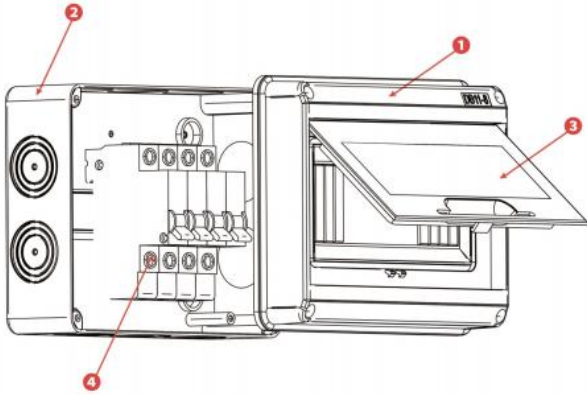

- ❶ Cover
- ❷ Base
- ❸ Window
- ❹ MCB

Product Details

